

# Analyzing Radio Technologies in Terms of Disturbances

Report by H. Viittala

Ajoneuvon / työkoneen langattomat lähiverkot (ALMA)

Version	Date	Author	Status	Notes
0.1	12.5.2009	HV	Draft	Document created
1.0	29.5.2009	HV	Proposal	Sent to Juha I.
1.1	4.6.2009	HV	Proposal	Updated
1.2	25.6.2009	Jl	Proposal	Update and additions
1.3	06.08.2009	Jl	Draft	Grammar correction
2.0	07.08.2009	Jl	Accepted	

## TERMS AND ABBREVIATIONS:

$(\cdot)^{-1}$	Matrix Inversion
$Q(\cdot)$	Q-Function
$\alpha$	Attenuation Factor
$\epsilon_b$	Bit Energy
$B$	System Bandwidth
$B_c$	Channel Coherence Bandwidth
$H$	Channel Matrix
$N_0$	Noise Power Spectral Density
$N_r$	Receive Antenna
$N_t$	Transmit Antenna
$P_b$	Bit Error Probability
$s_{Nt}$	Transmitted Symbol
$t_m$	Delay Spread
$x_{Nr}$	Received Symbol
2G	Second Generation
AMP	Alternate MAC/PHY
ARQ	Automatic Repeat-request
ASK	Amplitude Shift Keying
AWGN	Additive White Gaussian Noise
BCH	Bose-Chaudhuri-Hocquenghem
BPM	Burst Position Modulation
BPSK	Binary Phase Shift Keying
CC	Convolutional Coding
CEPT	European Conference of Postal and Telecommunication
CSS	Chirp Spread Spectrum
DAA	Detect and Avoid
DCM	Dual Carrier Modulation
DPSK	Differential PSK
DQPSK	Differential QPSK
DS	Direct Sequence
DSSS	Direct Sequence Spread Spectrum
EC	European Commission
ECC	Electronic Communications Committee
EIRP	Effective Isotropically Radiated Power
EM	Electromagnetic
ERO	European Radiocommunication Office
ETSI	European Telecommunications Standards Institute
FCC	Federal Communications Committee
FDD	Frequency Division Duplex
FDS	Frequency Domain Spreading
FEC	Forward Error Correction
FFI	Fixed Frequency Interleaving
FHSS	Frequency Hopping Spread Spectrum
GFSK	Gaussian Frequency Shift Keying
GPS	Global Positioning System
GSM	Global System for Mobile Communications
ISI	Intersymbol Interference
ISM	Industrial, Scientific and Medical
ITS	Intelligent Transportation System
ITU	International Telecommunication Union

ITU-R	International Telecommunication Union Radiocommunication Sector
LOS	Line-Of-Sight
LPD	Low-Probability-of-Detect
LPDC	Low Density Parity Check
LPI	Low-Probability-of-Intercept
MC	Multicarrier
MIMO	Multiple-Input Multiple-Output
MPC	Multipath Component
NFC	Near Field Communication
OFDM	Orthogonal Frequency Division Multiplexing
O-QPSK	Offset-QPSK
PAPR	Peak-to-Average Power Ratio
PPS	Precise Positioning System
PSK	Phase Shift Keying
PSSS	Parallel Sequence Spread Spectrum
QAM	Quadrature Amplitude Modulation
QPSK	Quaternary Phase Shift Keying
RFID	Radio Frequency Identification
RS	Reed-Solomon
RX	Receiver
SIG	Special Interest Group
SISO	Single-Input Single-Output
SPS	Standard Positioning System
SS	Spread Spectrum
TDD	Time Division Duplex
TDS	Time Domain Spreading
TFC	Time-Frequency Code
TFI	Time-Frequency Interleaving
TG	Task Group
TX	Transmitter
UMTS	Universal Mobile Telecommunication System
UN	United Nations
U-NII	Unlicensed National Information Infrastructure
UTRA	Universal Terrestrial Radio Access
UWB	Ultra Wideband
Wi-Fi	Wireless Fidelity
WLAN	Wireless Local Area Network
WPAN	Wireless Personal Area Network

# TABLE OF CONTENTS

1. INTRODUCTION .....	6
2. FREQUENCY REGULATIONS .....	7
2.1. REGULATION BODIES IN EUROPE .....	7
2.2. UNLICENSED FREQUENCY BANDS .....	8
2.2.1. ISM .....	8
2.2.2. U-NII .....	8
2.2.3. UWB .....	9
2.2.4. ITS .....	9
2.3. LICENSED FREQUENCY BANDS .....	9
2.3.1. GPS .....	9
2.3.2. GSM .....	9
2.3.3. UMTS .....	10
2.4. SUMMARY .....	10
3. ANALYZED TECHNOLOGIES .....	11
3.1. PHYSICAL LAYER TOPICS .....	11
3.1.1. Narrowband vs. wideband system .....	11
3.1.2. Spread-spectrum vs. multicarrier .....	12
3.1.3. SISO vs. MIMO .....	13
3.1.4. Channel coding .....	15
3.1.5. Modulation .....	16
3.2. WPAN .....	18
3.2.1. Ultra Wideband .....	18
3.2.2. Bluetooth .....	21
3.3. WLAN (IEEE 802.11x) .....	22
3.4. RFID AND NFC .....	24
4. CONCLUSION .....	25
5. REFERENCES .....	26

## LIST OF FIGURES

FIGURE 1. HETEROGENEOUS AIR INTERFACE OF A WORKING ENVIRONMENT. ....	6
FIGURE 2. SIMPLIFIED DIAGRAM OF FREQUENCY REGULATION BODIES IN EUROPE.....	7
FIGURE 3. SPECTRUM ALLOCATION OF THE STUDIED SYSTEMS. ....	10
FIGURE 4. IMPACT OF THE RADIO CHANNEL ON NARROWBAND AND WIDEBAND SYSTEMS.....	11
FIGURE 5. SIGNAL SPREADING AND DESPREADING IN PRESENCE OF NARROWBAND INTERFERENCE.....	13
FIGURE 6. MIMO SYSTEM. ....	14
FIGURE 7. MIMO SYSTEM IN A LOS CHANNEL. ....	15
FIGURE 8. MODULATION SCHEMES.....	17
FIGURE 9. WORLD-WIDE REGULATIONS OF UWB. ....	20

## LIST OF TABLES

TABLE 1. POWER LIMITS FOR U-NII BANDS .....	8
TABLE 2. UWB REGULATIONS IN EUROPE AND THE USA .....	9
TABLE 3. GSM (MOBILE STATION) FREQUENCIES IN EUROPE AND THE USA .....	10
TABLE 4. NARROWBAND VS. WIDEBAND.....	12
TABLE 5. SPREAD SPECTRUM VS. MULTICARRIER.....	13
TABLE 6. SISO VS. MIMO.....	15
TABLE 7. COMPARISON BETWEEN STUDIED CODING SCHEMES .....	16
TABLE 8. PERFORMANCE OF COHERENT SCHEMES UNDER RAYLEIGH FADING CHANNEL .....	18
TABLE 9. PARAMETERS OF ECMA-368 STANDARD .....	18
TABLE 10. FREQUENCY BANDS AND DATA RATES OF IEEE 802.15.4 AND IEEE 802.15.4A.....	21
TABLE 11. DATA RATE MODES OF BLUETOOTH.....	22
TABLE 12. POWER CLASSES OF BLUETOOTH .....	22
TABLE 13. 802.11A TRANSMIT POWER LEVELS.....	23
TABLE 14. WLAN TYPES .....	23
TABLE 15. 802.11A PARAMETERS.....	23

## 1. Introduction

Wireless communication has become widespread. Wi-Fi (WLAN) and Bluetooth are being used almost everywhere. Both of these are operating in the unlicensed 2.4 GHz and 5 GHz band, which is also popular among other technologies. This brings out a discussion about coexistence issues. What are the limits for non-interfering communication? Even a single working post can include a wide set of wireless technologies as illustrated in Figure 1. The disposition of devices and antennas has major impact on other systems. For instance, when high-power GSM (~2 W) is used near to low-power ZigBee (~1 mW) a ZigBee link will probably collapse.

In this document, the focus is on analyzing selected technologies in terms of disturbances. The document is organized as follows; Chapter 2 gives an insight to spectrum regulation bodies and frequency ranges of unlicensed, and some licensed frequency bands, focusing on Europe. In Chapter 3, selected technologies are analyzed. The document is concluded in Chapter 4.



Figure 1. Heterogeneous air interface of a working environment.

## 2. Frequency regulations

In this Chapter, the frequency regulations are presented in short by focusing on Europe. The regulation bodies of Europe, and unlicensed and licensed frequency bands related to the ALMA project are discussed. The unlicensed bands can be described as a common property shared by all communication parties, whereas the licensed bands are owned by companies.

### 2.1. Regulation bodies in Europe

The International Telecommunication Union (ITU) is the leading United Nations (UN) agency for information and communication issues. Managing of the international radio-frequency spectrum is allocated to the ITU Radiocommunication sector (ITU-R). ITU-R develops standards for radiocommunication systems, along with spectrum management. [1]

In Europe, the European Conference of Postal and Telecommunication Administration (CEPT) is responsible for regulation issues in compliance with the framework of the ITU-R radio regulations [2]. A political point of view is represented by the European Commission (EC). It drafts legislation and presents legislative proposals to the European Parliament and the Council. In addition, legislation is implemented by the EC.

The European Telecommunications Standards Institute (ETSI) was created by CEPT [3]. All telecommunication standardization activities of CEPT were transferred to ETSI. The Electronic Communications Committee (ECC) was also established by CEPT. ECC brings together regulatory administrations of the CEPT member countries. Its main tasks are to develop policies on electronic communications activities and harmonize the efficient use of the radio spectrum [3]. The work of ECC is supported by the European Radiocommunication Office (ERO) [4]. For instance, ERO distributes all the ECC documentations via its website [5]. The simplified diagram of regulation bodies and connections between them is illustrated in Figure 2.

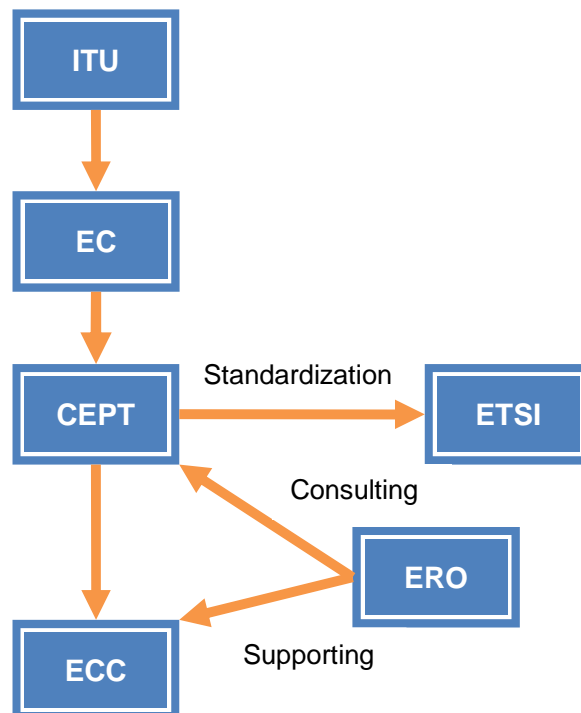

Figure 2. Simplified diagram of frequency regulation bodies in Europe.

## 2.2. Unlicensed frequency bands

### 2.2.1. ISM

ITU defines the industrial, scientific and medical (ISM) radio bands in 5.138, 5.150 and 5.280 of the Radio Regulations. In 5.138, the frequencies designated for ISM applications are [6]:

- 6765 – 6795 kHz,
- 433.05 – 434.79 MHz in region 1,
- 61 – 61.5 GHz,
- 122 – 123 GHz and
- 244 – 246 GHz.

The region 1 comprises Europe, Africa, the Middle East, the west of the Persian Gulf, the former Soviet Union and Mongolia, whereas the Americas and some of the eastern Pacific Islands are covered in the region 2. The following frequencies are also dedicated for ISM application in 5.150 [1]:

- 13553 – 13567 kHz,
- 26957 – 27283 kHz,
- 40.66 – 40.70 MHz,
- 902 – 928 MHz in region 2,
- 2400 – 2500 MHz,
- 5725 – 5875 MHz and
- 24 – 24.25 GHz.

In Europe, CEPT has adopted the maximum limits of effective isotropically radiated power (EIRP) of non-specific short range devices in 2400 – 2500 MHz and 5725 – 5875 MHz bands to be 10 mW and 25 mW, respectively. Video applications are only allowed to operate over 2.4 GHz frequencies. [7]

### 2.2.2. U-NII

In the USA, the Federal Communications Committee (FCC) makes available 300 MHz of spectrum at 5.15 – 5.35 GHz and 5.725 – 5.825 GHz for unlicensed equipments called unlicensed national information infrastructure (U-NII) devices. The devices provide short range, high-speed wireless digital communication. The available spectrum is divided in three bands having the power limitations presented in Table 1. [8]

Table 1. Power limits for U-NII bands

Band [GHz]	Max. peak power [mW]	Max. peak power spectral density [mW/MHz]
5.15 – 5.25	50	2.5
5.25 – 5.35	250	12.5
5.725 – 5.825	1000	50

### 2.2.3. UWB

The FCC was the first regulation authority defining ultra wideband (UWB) and its frequency range and power density limits. The UWB signal was defined to be a signal having the fractional bandwidth more than 0.20 or bandwidth more than 500 MHz. The allocated spectrum of UWB is from 3.1 to 10.6 GHz with the power spectral density of -41.3 dBm/MHz. [9]

In Europe, UWB was specified in 2007. It has been allocated to the frequency range from 6.0 to 8.5 GHz having the maximum mean EIRP density of -41.3 dBm/MHz. Besides the frequency range, the definition of UWB differs from the FCC, a signal is classified as UWB if its bandwidth is more than 50 MHz. [10]

Table 2. UWB regulations in Europe and the USA

Geographic Location	Frequency Range [GHz]	Max. power spectral density [dBm/MHz]
Europe	6.0 – 8.5	-41.3
USA	3.1 – 10.6	-41.3

### 2.2.4. ITS

The frequency spectrum within the band of 5.875 – 5.925 GHz has been designated for intelligent transport systems (ITS) by CEPT in Europe. The maximum EIRP for an ITS station is limited to 23 dBm/MHz. [11]

## 2.3. Licensed frequency bands

### 2.3.1. GPS

The global positioning system (GPS) is a space-based radionavigation system. GPS provides two positioning services; the precise positioning service (PPS) is available primarily to the US military and its allies, whereas the standard positioning service (SPS) provides less accurate positioning for civil and other users. A GPS satellite transmits signals with the frequencies of 1547.42 MHz and 1227.6 MHz known as the L1 and L2 signals, respectively. The signals are transmitted with enough power to ensure the minimum signal power level of -160 dBw (L1) and -166 dBw (L2) at the Earth's surface. [12]

### 2.3.2. GSM

The Global System for Mobile Communications (GSM), known as the second generation (2G) cellular system, is the most popular system for mobile phones in the world. The frequency ranges for Europe and the USA are summarized in Table 3. [13,14,15]

Table 3. GSM (Mobile station) frequencies in Europe and the USA

Geographical Location	Link	Frequency Band [MHz]	Maximum Nominal Output Power [W]	Reference Receiver Sensitivity [dBm]
Europe	900 uplink	890 – 915	2 (33 dBm)	-
	900 downlink	935 – 960	-	-102
	1800 uplink	1710 – 1785	1 (30 dBm)	-
	1800 downlink	1805 – 1880	-	-102
USA	850 uplink	824 – 849	2 (33 dBm)	-
	850 downlink	869 – 894	-	-102
	1900 uplink	1850 – 1910	1 (30 dBm)	-
	1900 downlink	1930 – 1990	-	-102

### 2.3.3. UMTS

The universal mobile telecommunication system (UMTS) technical specifications defined by 3GPP include two air interfaces for universal terrestrial radio access (UTRA), i.e., frequency division duplex (FDD) [16] and time division duplex (TDD) [17]. The FDD solution seems to have the greatest deployment especially in Europe and the Americas, whereas the TDD solution is primarily adapted in Asia. [13] The frequency bands 1900 – 1980 MHz, 2010 – 2025 MHz and 2110 – 2170 MHz is designed for terrestrial UMTS in Europe [18].

### 2.4. Summary

The spectrum regulations were briefly discussed in this Chapter to gain understanding of frequency ranges and power limits of the possible systems applied in the ALMA-project. The unlicensed spectrums, i.e., ISM, U-NII, UWB and ITS and licensed frequency bands of GPS, GSM and UMTS were introduced. In Figure 3, the spectrum allocation of the studied systems is presented.

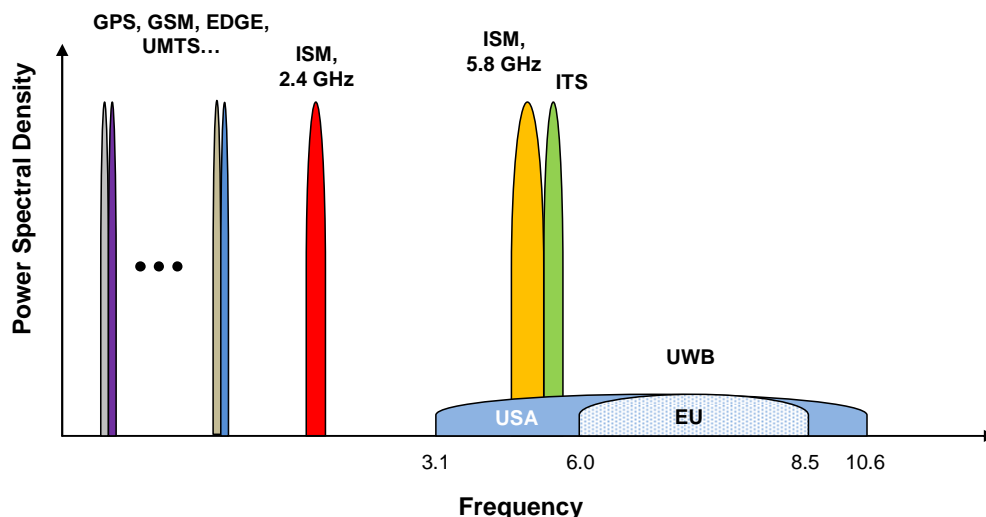

Figure 3. Spectrum allocation of the studied systems.

### 3. Analyzed technologies

#### 3.1. Physical layer topics

##### 3.1.1. Narrowband vs. wideband system

The most convenient way to classify a system either to be narrowband or wideband is to take a look at channel characteristics. If the bandwidth of the system ( $B$ ) is larger than the coherence bandwidth of the channel ( $B_c$ ), the system is wideband or ultra wideband. When the bandwidth of the system is increased over the channel coherence bandwidth, multipath components of the channel become separable. Resolvable multipath components (MPC) bring out an extra time diversity scheme to be exploited, but it also increases the duration of the received signal because of multipath delay spread ( $t_m$ ) leading to intersymbol interference (ISI). In the case of a wideband system, spread spectrum and multicarrier techniques avoid ISI mostly by changing the characteristics of the transmitted signal. Nevertheless, they still suffer from multipath distortion due to the frequency-selective channel, i.e., the channel is not constant over the symbol bandwidth. In Figure 4, separation of the MPCs and phenomenon of ISI are illustrated. [19-21]

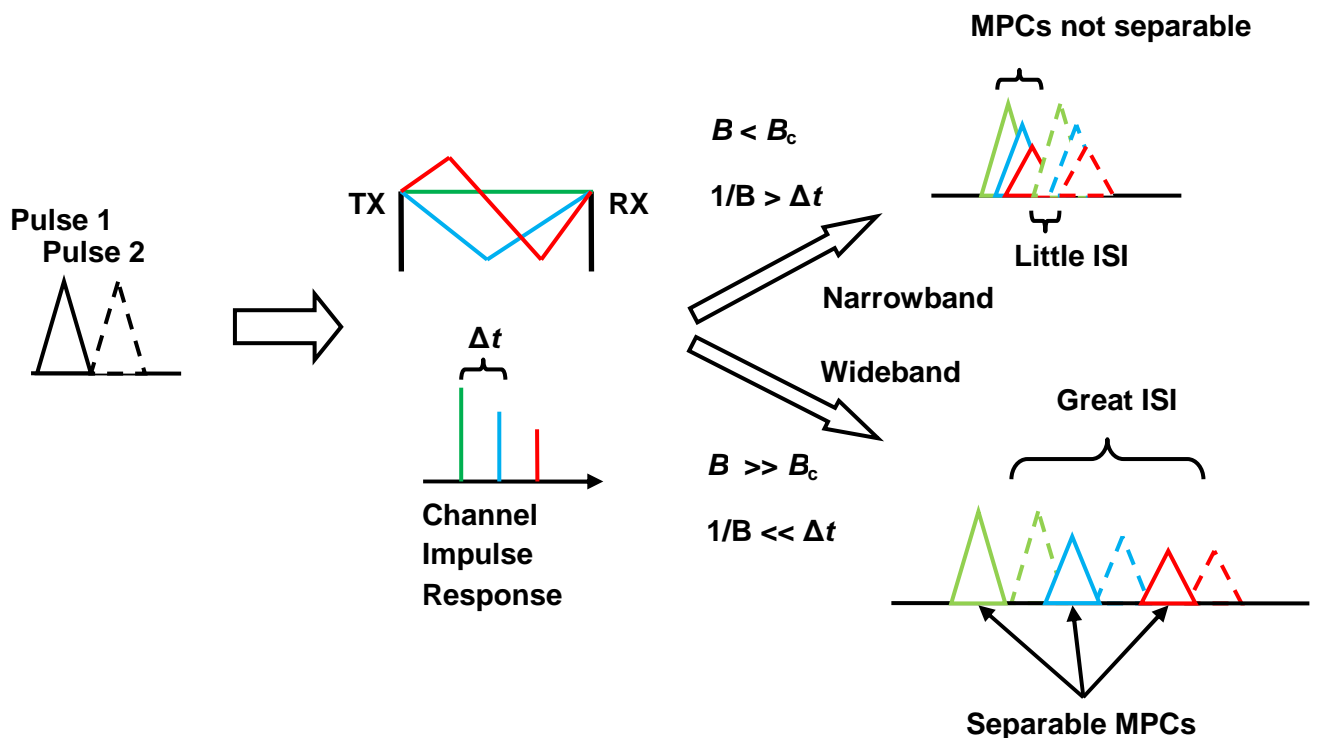

Figure 4. Impact of the radio channel on narrowband and wideband systems.

Since a narrowband system is operating in a non-selective frequency channel, it is possible to use simple one-tap equalization in a receiver. A narrowband system is typically designed for low data rate applications, whereas a wideband system provides higher data rates due to larger bandwidths. The wider bandwidth brings out an issue of coexistence. Especially in the case of UWB, it is almost certain that there is another system within its operating bandwidth. [19-21]

Table 4. Narrowband vs. wideband

	Narrowband	Wideband
Advantages	Little ISI	Increased data rate
Disadvantages	Low rate	Increased level of ISI, coexistence

### 3.1.2. Spread-spectrum vs. multicarrier

The bandwidth of the transmitted signal is intentionally increased to reduce the effect of ISI and narrowband interference in the case of spread-spectrum (SS) technique. The most common way to form spread spectrum is to apply direct sequence (DS) where data is multiplied by a pseudorandom sequence. The reduction of impact of narrowband interference is illustrated in Figure 5. Spread-spectrum approach is also utilized for hiding it by transmitting it at low power making it low-probability-of-detect and low-probability-of-intercept (LPD/LPI) signal. In spread spectrum systems, code acquisition and tracking process are the hardest part of receiver implementation leading to complex signal processing. [20,21]

In a multicarrier (MC) scheme, serial high rate data stream is split into several parallel, low rate substreams. These substreams are sent simultaneously over orthogonal subchannels. The number of subchannels is chosen so that the bandwidth of each subchannel is smaller than the channel coherence bandwidth. Hence, each subchannel experiences frequency flat fading channel and relatively small ISI. Multicarrier scheme is efficiently implemented with orthogonal frequency division multiplexing (OFDM). In OFDM, ISI is eliminated almost completely by the use of cyclic prefix. OFDM technique is widely adapted to wireless systems, e.g., IEEE 802.11a/n (WLAN) and IEEE 802.16 (WiMAX). [22]

OFDM is an efficient way to deal with multipath. With given delay spread, its implementation complexity is much lower than a single carrier system with an equalizer. It also offers high spectral efficiency by allowing subchannels to overlap. Since all subcarriers experiences flat fading, performance can degrade seriously if one or more subchannels are in deep fade. To compensate the possibility of deep fade, it is important to use channel coding with interleaving, frequency equalization, precoding or adaptive loading. OFDM suffers from relative large peak-to-average power ratio (PAPR) reducing the efficiency of the RF power amplifier. [22]

In [23], single user multicarrier spread spectrum (MC-SS) and direct sequence (DS) SS are studied in the presence of narrowband interference and multipath fading. The conclusion is that characteristics of spreading code have major impact on performance of DS-SS. In overall, MC-SS outperforms DS-SS, but when the spreading code is correctly designed the performance difference comes negligible. This requires either the use of codes with perfect periodic autocorrelation function, hopping between codes, or long codes.

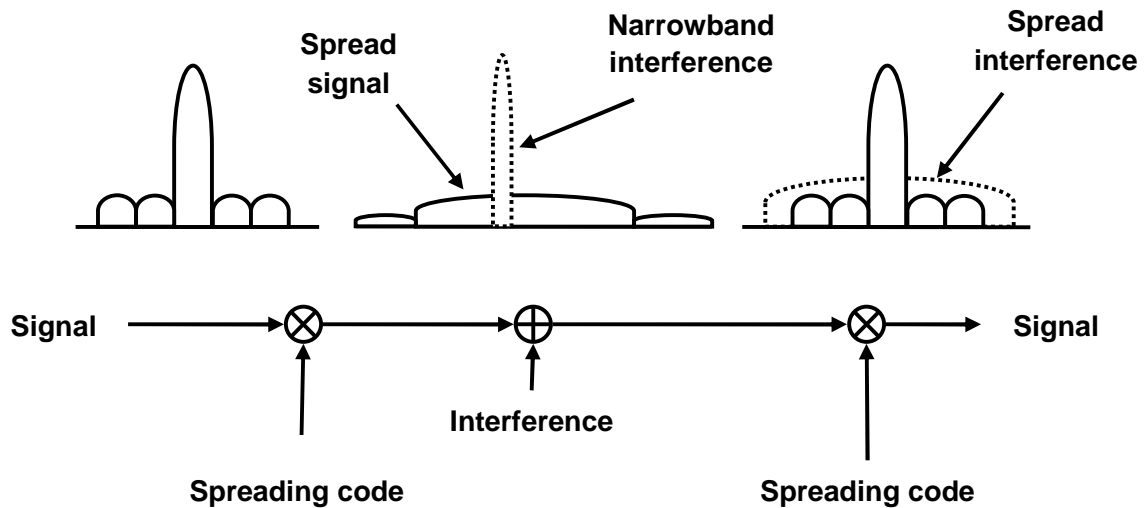

Figure 5. Signal spreading and despreading in presence of narrowband interference.

Table 5. Spread spectrum vs. multicarrier

	Spread Spectrum (DS)	Multicarrier (OFDM)
Advantages	robust against multipath and narrowband interference, LPD/LPI	robust against multipath and narrowband interference
Disadvantages	complex signal processing	sensitive to frequency offset and phase noise, large PAPR

### 3.1.3. SISO vs. MIMO

Single-input single-output (SISO) is a system exploiting one antenna pair, i.e., one spatial dimension.

In multiple-input multiple-output (MIMO) communication, the idea is to transmit and receive multiple streams of data on multiple transmit and receive antennas. MIMO can be applied for rate maximization, diversity maximization or jointly maximization of rate and diversity. Since MIMO exploits space dimension in both transmitter and receiver, the channel becomes a matrix.

The following example describes a MIMO system applied for spatial multiplexing (rate maximization). The MIMO system is illustrated in Figure 6 where  $s_{N_T}$  is the transmitted symbol for  $N_T$  transmit antenna, TX refers to the transmitter,  $\mathbf{H}$  is the channel matrix, the receiver is referred to as RX,  $N_r$  is the number of receive antennas and  $x_{N_r}$  is the received symbol. [24]

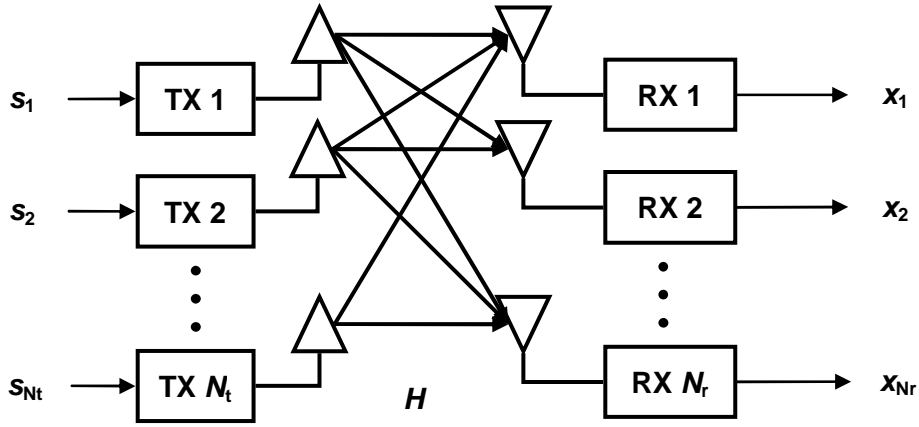

Figure 6. MIMO system.

The matrix representation for the output of the MIMO system at the time instant  $t$  is given by

$$\mathbf{x}(t) = \mathbf{H}(t)\mathbf{s}(t) \quad (1)$$

where

$$\mathbf{s}(t) = \begin{pmatrix} s_1(t) \\ s_2(t) \\ \vdots \\ s_{N_t}(t) \end{pmatrix}, \mathbf{x}(t) = \begin{pmatrix} x_1(t) \\ x_2(t) \\ \vdots \\ x_{N_r}(t) \end{pmatrix} \text{ and } \mathbf{H}(t) = \begin{pmatrix} h_{11}(t) & h_{12}(t) & \cdots & h_{1,N_t}(t) \\ h_{21}(t) & h_{22}(t) & \cdots & h_{2,N_t}(t) \\ \vdots & \vdots & \ddots & \vdots \\ h_{N_r,1}(t) & h_{N_r,2}(t) & \cdots & h_{N_r,N_t}(t) \end{pmatrix}. \quad (2)$$

If the channel matrix  $\mathbf{H}(t)$  is invertible, the transmitted symbols can be solved by using the matrix inversion

$$\mathbf{s}(t) = \mathbf{H}(t)^{-1}\mathbf{x}(t) \quad (3)$$

Therefore, the channel matrix must be known at the receiver. Typically, this is made possible by sending the predefined training sequence. The inverse of the square matrix  $\mathbf{H}(t)$  is the matrix  $\mathbf{H}^{-1}(t)$  such that [25]

$$\mathbf{H}(t)\mathbf{H}(t)^{-1} = \mathbf{I}, \quad (4)$$

where  $\mathbf{I}$  is the identity matrix.

The square channel matrix  $\mathbf{H}(t)$  is invertible if its determinant is non-zero. The antenna correlation and the dominant line-of-sight (LOS) component of the channel degrade the orthogonality of the channel matrix yielding to performance degradation. For instance, when the distance between the transmitter and the receiver is long enough and there is a strong LOS component, the rank of the channel matrix approach one and the matrix becomes non-invertible as it is illustrated in Figure 7

and Eq. (5) [26]. It becomes evident, that the performance of the spatial multiplexed MIMO system is very sensitive to channel matrix invertibility.

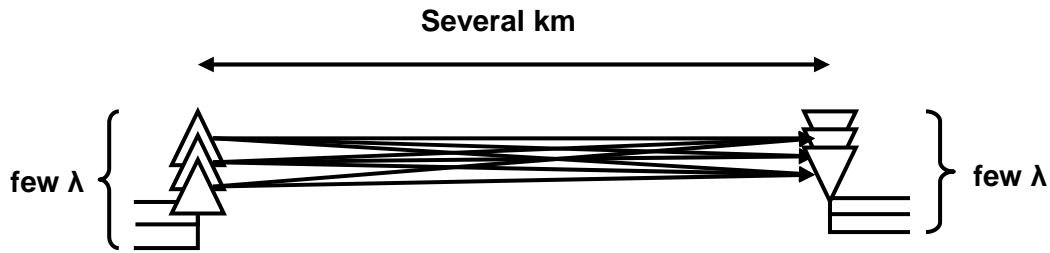

Figure 7. MIMO system in a LOS channel.

The channel matrix is

$$\mathbf{H}(t) \approx \alpha \begin{bmatrix} 1 & 1 & 1 \\ 1 & 1 & 1 \\ 1 & 1 & 1 \end{bmatrix} \quad (5)$$

where  $\alpha$  is the attenuation factor. The channel matrix  $\mathbf{H}$  is non invertible, and therefore transmitted symbols cannot be solved.

Table 6. SISO vs. MIMO

	SISO	MIMO
Advantages	Simple	Increased rate or diversity
Disadvantages	Does not exploit space dimension	Very sensitive to channel conditions, computational complexity,

### 3.1.4. Channel coding

Channel coding provides capability to detect or/and correct errors occurred in a wireless channel due to noise and interference. There are two types of channel coding schemes

- automatic repeat-request (ARQ): Receiver request a retransmission of erroneous data.
- forward error correction (FEC): Transmitted data is encoded with error-correction code.

In fading channels, errors typically occur in bursts. Therefore, interleaving is mostly applied with channel coding to randomize the location of errors. [27]

In this review, we are focusing on the FEC coding since there is a real-time requirement in the ALMA-project. The coding schemes are shortly introduced.

#### Linear block codes

A linear block code applies parity bits to either detect more than one error or correct for one or more errors. The cost of error correction or detection is either bandwidth expansion or lower data

rate. The most common block codes are Hamming, Golay and its extension, Bose-Chaudhuri-Hocquenghem (BCH), and Reed-Solomon (RS) codes.

### Convolutional codes

In convolutional coding, code words are generated by passing information bits through a linear finite-state shift register. This introduces memory for a code. The Viterbi decoding algorithm was discovered to reduce the complexity of maximum likelihood decoding.

### Turbo codes

Turbo codes are very powerful codes that almost gain the Shannon capacity limit in additive white Gaussian noise (AWGN) channel. They consist of two key components: parallel concatenated encoding and iterative decoding. Turbo codes can be implemented with two convolutional encoders separated by interleaver.

### Low density parity check codes

Low density parity check (LDPC) code can be classified as a linear block code which has a particular structure for a parity check matrix. If a codeword is long enough, LDPC codes almost reach the Shannon limit.

### Summary

This section shortly introduced the most common channel coding schemes. The comparison between coding schemes is presented in Table 7.

Table 7. Comparison between studied coding schemes

		Block code	Convolutional	Turbo	LDPC
Complexity	Encoding	+	++	+++	++++
	Decoding	+	++	++++	+++
Correction capability		+(+)	+++	++++	++++

For further information about channel coding:

- Linear block codes: [20], [21], [27], [28]
- Convolutional codes: [20], [21], [27], [28]
- Turbo codes: [29], [20], [21], [27], [28]
- LDPC codes: [30], [20], [21], [27], [28].

### 3.1.5. Modulation

In digital modulation, data bits are mapped to a transmitted signal according to a specified constellation. This is illustrated in Figure 8 where data bit '1' is mapped to the signal  $s_1(t)$  and bit '0' to the signal  $s_2(t)$  in the case of binary phase shift keying (BPSK). In quaternary phase shift keying (QPSK), 2 bits are mapped per signal, whereas 4 bits are reserved per signal in the case of quadrature amplitude modulation (QAM). Digital modulation has several benefits compared to analog modulation [21]:

- High data rate,
- High spectral efficiency,
- High power efficiency,

- Robustness to channel impairments and
- Lower power/cost consumption.

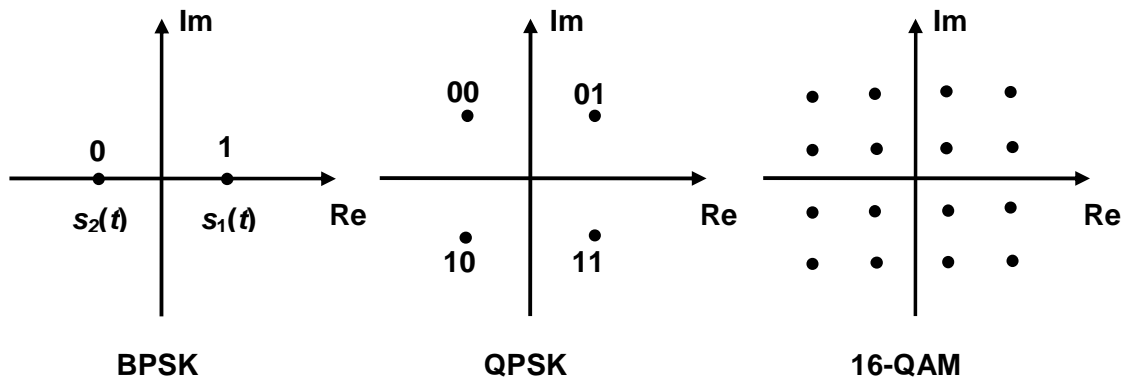

Figure 8. Modulation schemes.

It can be shown that error rate performance of any digital modulation scheme is bounded to the Euclidean distance between transmitted waveforms in AWGN channel with noise power spectral density  $N_0$ . This leads to the following bit error probabilities ( $P_b$ ) defined by using the Q-function [20]

$$P_{b,\text{BPSK}} = Q\left(\sqrt{\frac{2\varepsilon_b}{N_0}}\right), \quad (6)$$

$$P_{b,\text{QPSK}} = Q\left(\sqrt{\frac{\varepsilon_b}{N_0}}\right), \quad (7)$$

where  $\varepsilon_b$  is the bit energy. From Eq. (6) and (7), it can be seen that QPSK needs 3 dB more energy ( $10\log_{10}(2) = 3$  dB) per bit to gain bit error probability of BPSK. The difference occurs due to the distance between constellation points.

To perceive a more realistic view on the performances of digital modulations, Table 8 summarizes the bit error probabilities of the modulations under Rayleigh fading channel [21]. Rayleigh fading is a statistical channel model for non-LOS environments. When taps of an impulse response of a channel are modeled as a complex-valued Gaussian with zero-mean, then a magnitude of each tap is Rayleigh distributed. [21]

Table 8. Performance of coherent schemes under Rayleigh fading channel

Scheme	Bit Error Probability	Data Rate [bits/Hz/s]
Coherent BPSK	$1/(4 \times \text{SNR})$	1
Coherent QPSK	$1/(2 \times \text{SNR})$	2
Coherent 16-QAM	$5/(2 \times \text{SNR})$	4

There are more sophisticated digital modulations than the presented ones, e.g., non-linear, coded and modulations with memory, but the studied modulations are included to many standards, and therefore are considered here.

### 3.2. WPAN

#### 3.2.1. Ultra Wideband

UWB systems can be categorized into two classes: singleband or multiband. In singleband UWB, the data is spread over an entire allocated bandwidth, whereas a fraction of total bandwidth and hopping between fractions are applied in the case of multiband UWB.

##### *Multiband UWB: ECMA-368*

The ECMA-368 standard for high data rate UWB is based on the WiMedia Alliance solution [31]. In the standard, the UWB band defined by the FCC is divided into 14 subbands each having the bandwidth of 528 MHz. In each subband, OFDM technique with the total of 110 subcarriers and 12 pilot subcarriers is utilized. To gain optimum performance under variety channel conditions, forward error coding (convolutional coding), frequency domain spreading (FDS) and time domain spreading (TDS) are applied. Hopping patterns are defined by time-frequency codes (TFC). When information is interleaved over three bands, TFC is referred as time-frequency interleaving (TFI), whereas fixed frequency interleaving (FFI) means transmitting on a single band.

The standard uses three-stage interleaving to provide robustness against burst errors: symbol interleaving, intra-symbol tone interleaving and intra-symbol cyclic shifts. In dual carrier modulation (DCM), data is mapped into two 16-QAM symbols mapped to different subcarriers to gain diversity for high data rates. The prefix of 70.08 ns is added in each OFDM symbol to mitigate ISI. The parameters for data rates are summarized in Table 9.

Table 9. Parameters of ECMA-368 standard

Data Rate [Mbps]	Modulation	Coding Rate	FDS	TDS	Minimum Receiver Sensitivity [dBm]
53.3	QPSK	1/3	YES	YES	-80.8
80	QPSK	1/2	YES	YES	-78.9
106.7	QPSK	1/3	NO	YES	-77.8
160	QPSK	1/2	NO	YES	-75.9
200	QPSK	5/8	NO	YES	-74.5
320	DCM	1/2	NO	NO	-72.8
400	DCM	5/8	NO	NO	-71.5
480	DCM	3/4	NO	NO	-70.4

In PHY layer, the standard defines two levels of security: no security or strong security. Strong security includes data encryption, message integrity and replay attack protection.

Due to the ultra wide spectrum need, the world-wide regulations vary in many respects. In Figure 9, the UWB regulations in different geographical locations are illustrated. As it can be seen, only band group 6 is a common one. [32]

Frequency hopping provides an effective tool for interference mitigation. When a system detects a wideband interference source in its operating band, it can detect and avoid (DAA) this band by changing the TFC. A DAA mechanism can be realized by using spectrum sensing where secondary devices sense the presence of the primary user and use the spectrum only if it is free [33].

On March 16<sup>th</sup> 2009 the WiMedia Alliance transferred all current and future specifications to the Bluetooth Special Interest Group (SIG), Wireless USB Promoter Group and the USB Implementers Forum. When the transfer is successfully completed, the WiMedia Alliance will cease operations of marketing and administrative items. [32] Hence, the future of WiMedia's multiband UWB is open.

The market of UWB chipsets and UWB itself has been in turbulence during the last year and half. Several semiconductor companies have ended their operations related to UWB. WiQuest, Intel and Tzero have cancelled their UWB design efforts [34-36]. Despite of cloudy forecast for UWB, Staccato believes that UWB will soak up the sun and break itself through [37]. In-Stat predicts that UWB is gone by 2013 in consumer and computer markets but stands its ground in industrial and medical segment [38].

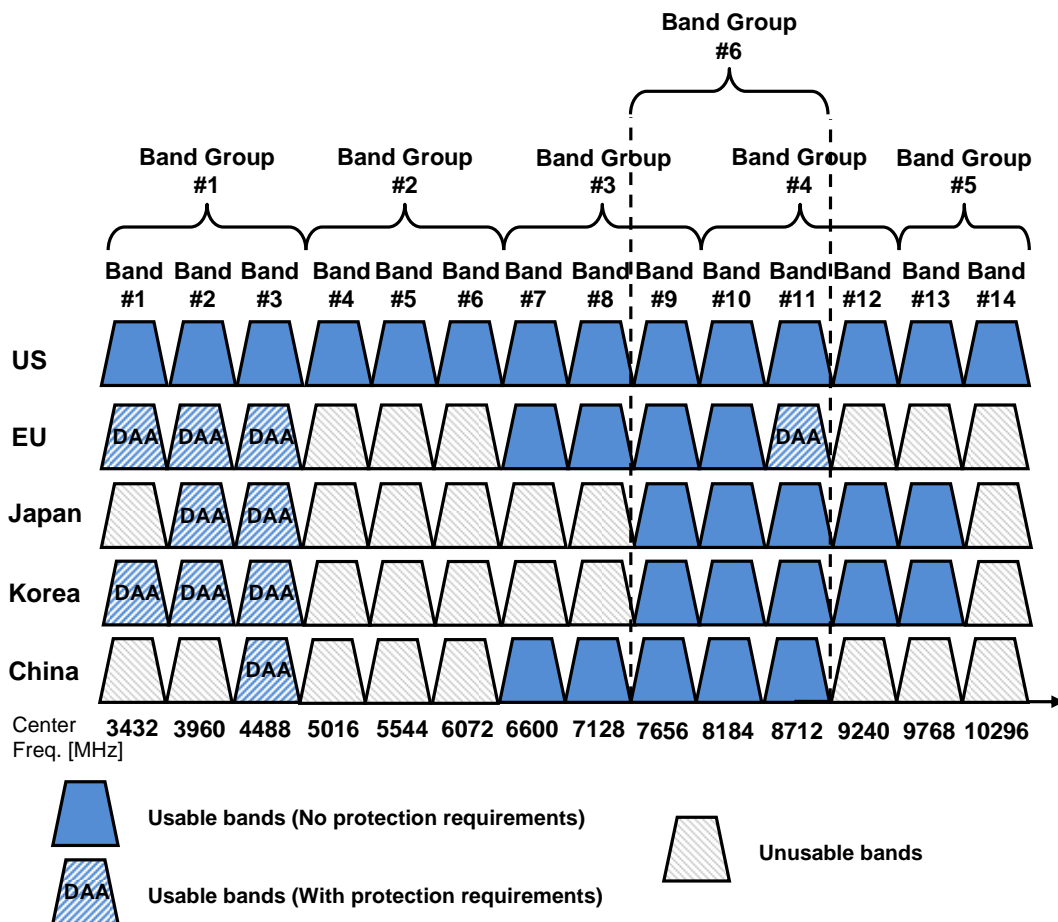

Figure 9. World-wide regulations of UWB.

### *Singleband UWB: ZigBee*

IEEE 802.15.4, known as ZigBee and lobbied by the ZigBee Alliance [39], is the standard for small and low-power radios for wireless personal area network (WPAN) [40]. The standard was amended by new PHY layers, e.g., UWB in [41]. The amendment is known as IEEE 802.15.4a. IEEE 802.15.4 and .4a are specified to operate in the following unlicensed frequency bands:

- 868 MHz (e.g., Europe),
- 915 MHz (e.g., North America),
- 2450 MHz (worldwide),
- 3.1 – 10.5 GHz (UWB band varies by region)
- sub-gigahertz band 250 – 750 MHz for UWB

The different PHY layers and related parameters are given in Table 10. The specification of the ZigBee Alliance is based on the IEEE 802.15.4, and thus does not include UWB yet [42].

Operation in the crowded 2.4 GHz ISM band upraises concern about coexistence. Possible users of the ISM band and therefore possible interferers include, e.g., WLAN, Bluetooth, WiMAX. The issue is widely studied and is summarized in, e.g., [41,42]. In coexistence studies, different methodologies and environments have been used, making a comparison difficult. Nevertheless, there seems to be a consensus about that distance between WLAN and ZigBee networks should be at least 2 m and frequency offset between the networks should be at least 20 MHz to attain reliable communication [44].

Security services for ZigBee provide methods for key establishment, key transport, frame protection and device management. Point-to-point communication is secured by 128-bit link key, while broadcast communication is secured by 128-bit network key. [42]

The strength of ZigBee is standard-based technology enabling its broad-based deployment worldwide. The majority of IEEE 802.15.4 devices are expected to operate with transmitted power between -3 dBm and 10 dBm, with 0 dBm being typical [40].

Table 10. Frequency bands and data rates of IEEE 802.15.4 and IEEE 802.15.4a

PHY [MHz]	Frequency Band [MHz]	Spreading	Modulation	FEC	Bit Rate [kbps]	Receiver Sensitivity [dBm]	
IEEE 802.15.4	868/915	868 – 868.6	DSSS	BPSK	-	20	-92.0
		902 – 928	DSSS	BPSK	-	40	-92.0
	868/915 (Optional)	868 – 868.6	DSSS	O-QPSK	-	100	-85.0
		902 – 928	DSSS	O-QPSK	-	250	-85.0
	868/915 (Optional)	868 – 868.6	PSSS	ASK	-	250	-85.0
		902 – 928	PSSS	ASK	-	250	-85.0
2450	2400 – 2483.5	DSSS	O-QPSK	-	250	-85.0	
IEEE 802.15.4a	2450 (Optional)	2400 – 2483.5	CSS	DQPSK	-	250	-91.0
	2450 (Optional)	2400 – 2483.5	CSS	DQPSK	-	1000	-85.0
	UWB sub-gigahertz (Optional)	250 – 750	UWB	BPM-BPSK	RS+CC	110 - 27240	-
	UWB low band (Optional)	3244 – 4742	UWB	BPM-BPSK	RS+CC	110 – 27240	-
	UWB high band (Optional)	5944 – 10 234	UWB	BPM-BPSK	RS+CC	110 – 27240	-

ASK = Amplitude Shift Keying  
 BPM = Burst Position Modulation  
 CC = Convolutional Coding  
 CSS = Shirp Spread Spectrum  
 DQPSK = Differential QPSK  
 O-QPSK = Offset-QPSK  
 PSSS = Parallel Sequence Spread Spectrum  
 RS = Reed-Solomon

### 3.2.2. Bluetooth

On June 14<sup>th</sup> 2002, IEEE 802.15 task group (TG) 1 derived the standard for WPAN based on the Bluetooth 1.1 foundation specifications [45]. Thus far, Bluetooth has been evolved to the version 3.0 which was released on 21<sup>st</sup> of April, 2009 [46]. The new version adapts the IEEE 802.11 radio protocol ([47]) increasing the throughput of data transfer [48]. In addition, the version realizes increasing power savings due to enhanced power control. Although UWB was anticipated as an alternate MAC/PHY (AMP) for Bluetooth 3.0, it was left out [49].

Bluetooth is operating in 2.4 GHz and 5 GHz (AMP) ISM bands and providing three data rate modes, i.e., mandatory basic mode having the bit rate of 1 Mbps, optional enhanced mode (2 and 3 Mbps) and AMP mode (up to 54 Mbps). The data rate related parameters and different power classed are summarized in Table 11 and Table 12, respectively. In Bluetooth, FEC and ARQ are applied for channel coding. The IEEE 802.11 standard is discussed in the next section in detail. [48]

Since Bluetooth applies ISM bands with its complementary technology, WLAN, coexistence issues comes up. Bluetooth and WLAN are often used in close proximity to one another. Bluetooth applies adaptive frequency hopping capability with nominal rate of 1600 hops/s to reduce interference between wireless technologies. The signal hops between 79 frequencies with 1 MHz intervals.

Coexistence between these systems is widely studied, e.g. [50–53]. The conclusion is that the coexistence impact of WLAN on Bluetooth and vice versa depends strongly on applied modes. For instance, does WLAN apply frequency hopping spread spectrum (FHSS) or direct sequence spread spectrum (DSSS), what is traffic distribution, etc. It is obvious that these systems have an impact to each other's performance, and the impact is very case-specific.

Bluetooth offers private 128-bit authentication key and from 8-bit to 128-bit encryption key for usage protection and information confidentiality. The security issues of Bluetooth are studied in [54].

Bluetooth has come to stay. Its popularity bases on the world-wide universal standard and easy plug&play operation. In spring 2009, 12000 member companies were members of the Bluetooth SIG. [46]

Table 11. Data rate modes of Bluetooth

Mode	Modulation	Bit Rate [Mbps]	Minimum Receiver Sensitivity [dBm]
Basic	GFSK	1	-70
Enhanced	$\pi/4$ -PSK	2	-70
	8-DPSK	3	-70
AMP (802.11)	FHSS, DSSS, OFDM	up to 54	see Sect. 3.3

\_\_\_\_\_

GFSK = Gaussian Frequency Shift Keying  
 PSK = Phase Shift Keying  
 DPSK = Differential PSK

Table 12. Power classes of Bluetooth

Power Class	Maximum Output Power [dBm]	Minimum Power [dBm]	Range [m]
1	20	0	100
2	4	-6	10
3	0	N/A	1

### 3.3. WLAN (IEEE 802.11x)

The IEEE 802.11x standard family, known also as WLAN or Wireless Fidelity (Wi-Fi), consists of over-the-air modulation techniques using the same basic protocol. In 2007, a new edition of IEEE 802.11 standard was published including amendments 1 – 8 (802.11a/b/d/g/h/i/j/e). [47]

WLAN operates at the 2.4 GHz ISM band, U-NII bands (USA) and 5.470 – 5.725 GHz band (Europe). The maximum transmitted power for 5 GHz bands are given in Table 13. WLAN applies several different PHY layer techniques; FHSS, DSSS, OFDM and MIMO-OFDM to attain data rates up to 600 Mbps as presented in Table 14. In addition, Table 15 summarizes modulation schemes, coding rates and receiver sensitivity levels for 802.11a. The IEEE 802.11n standard is still a draft version, and it has proceeded to the draft version 8.0 [56]. The general description of 802.11n is introduced, e.g., in [57].

Since WLAN also utilizes the crowded 2.4 GHz, interference from/to other wireless technologies is explicit. Coexistence of 802.11b and Bluetooth was discussed in the previous section, and it was concluded that interference strongly depends on various parameters. In 802.11n, the additional bandwidth is provided, i.e., 40 MHz, whereas the traditional 802.11 applies the bandwidth of 20 MHz. The impact of the wider bandwidth to the performance of Bluetooth is studied, e.g., in [56-59]. The results are equivalent to the previous ones; impact of one to other appears to be dependent on measurement or simulation setup. For instance, if 802.11n has low medium utilization, 802.11n and Bluetooth performance are not degraded considerably. When 802.11n has high medium utilization, performance of Bluetooth degrades. But if it applies adaptive frequency hopping, the performance is greatly improved.

As Bluetooth, WLAN has become popular due to the strong alliance, Wi-Fi Alliance [62]. It has more than 300 members, and there are more than 5000 product certifications completed to date.

Table 13. 802.11a transmit power levels

Frequency Band [GHz]	United States Maximum Output Power With up to 6 dBi Antenna Gain [mW]	Europe (EIRP) [mW] <sup>1</sup>
5.15 – 5.25	40 (2.5 mW/MHz)	200
5.25 – 5.35	200 (12.5 mW/MHz)	200
5.470 – 5.725	-	1000
5.725 – 5.825	800 (50 mW/MHz)	-

<sup>1</sup> ERC/DEC/(99)23 [55]

Table 14. WLAN types

WLAN Type	Frequency Range [GHz]	PHY Layer	Data Rate [Mbps]
802.11	2.4	FHSS/DSSS	1,2
802.11a	5	OFDM	6 – 54
802.11b	2.4	DSSS	1 – 11
802.11g	2.4	.11a + .11b	1 – 54
802.11n	2.4 + 5	MIMO-OFDM	up to 600

Table 15. 802.11a parameters

Data Rate [Mbps]	Modulation	Convolutional Coding Rate	Minimum Receiver Sensitivity [dBm]
6	BPSK	1/2	-82
9	BPSK	3/4	-81
12	QPSK	1/2	-79
18	QPSK	3/4	-77
24	16-QAM	1/2	-74
36	16-QAM	3/4	-70
48	64-QAM	2/3	-66
54	64-QAM	3/4	-65

### **3.4. RFID and NFC**

Radio frequency identification (RFID) is a very short range technology mainly used for identification from a short distance [63]. At the highest level, RFID devices can be classified to be either active or passive. Active devices require power to operate, whereas passive devices capture energy from a reader. Energy can be transferred by using magnetic induction or electromagnetic (EM) wave capture. Near-field coupling of reader and tag (device) is the most straightforward way to implement a passive RFID system. This is called near field communication (NFC). NFC is operating in the 13.56 MHz ISM band having data rates of 106, 212 and 424 kbps [64]. The operating range of NFC is considered to be 0 – 20 cm. Because of low transmission power, and short distance, and the operation in a less crowded ISM band, there are less coexistence issues.

## 4. Conclusion

We have studied some unlicensed, and licensed frequency bands that could be relevant for the ALMA project. In addition, regulation bodies and their relations in Europe were presented. After that, physical layer topics were studied in general, including comparison between narrowband and wideband, spread-spectrum and multicarrier, SISO and MIMO, different channel coding schemes, and various modulation techniques. General physical layer topics was followed by the analysis of technologies operating in the unlicensed frequency bands including ECMA-368, ZigBee, Bluetooth, WLAN and NFC.

Most of these systems operate in the crowded 2.4 GHz ISM band. This may lead to severe implications, especially in urban and sub-urban environments where the number of devices is increasing all the time. A working environment may include a heterogeneous group of wireless technologies leading to coexistence problems. As discussed, performance degradation due to coexistence depends strongly on applied parameters, e.g., is wireless communications used for voice traffic or data streaming.

The Wireless environment also sets other kind of challenges. In a hidden node problem, a station is visible to an access point, but invisible to one or more stations coupled with the access point. This will incur problems in media access control. Security issues also come up. A Wireless link should be secured from possible hijackers, which can be accomplished with various security and identification algorithms.

## 5. REFERENCES

- [1] International Telecommunication Union (ITU). [Online]. Available at: <http://www.itu.int/>.
- [2] The European Conference of Postal and Telecommunication Administration (CEPT). [Online]. Available at: <http://www.cept.org/>.
- [3] The European Telecommunications Standards Institute (ETSI). [Online]. Available at: <http://www.etsi.org/>.
- [4] The European Radiocommunication Office (ERO). [Online]. Available at: <http://www.ero.dk/>.
- [5] The European Radiocommunication Office (ERO) Document Database. [Online]. Available at: <http://www.erodocdb.dk/>.
- [6] International Telecommunication Union, Article 5 of the Radio Regulations.
- [7] The European Radiocommunications Committee (ERC), ERC Recommendation 70-03 (Tromsø and subsequent amendments) Relating to the Use of Short Range Devices (SDR), Doc: ERC/REC 70-03, 60 p., 2009.
- [8] The Federal Communication Commission (FCC), Amendment of the Commission's rule to Provide for Operation of Unlicensed NII devices in the 5 GHz Frequency Range. Doc: ET Docket No. 96-102, 55 p., 1997.
- [9] The Federal Communication Commission (FCC), Revision of Part 15 of the Commission's Rules Regarding Ultra-Wideband Transmission Systems. Doc: ET Docket 98-153, 118 p., 2002.
- [10] Commission of the European Communities, Commission Decision of 2/II/2007 on Allowing the Use of the Radio Spectrum for Equipment Using Ultra-Wideband Technology in a Harmonized Manner in the Community. 8 p., 2007.
- [11] The Electronic Communications Committee (ECC), Decision on the Harmonized use of the 5875 – 5925 MHz Frequency Band for Intelligent Transport Systems (ITS). Doc: ECC/DEC/(08)01, 5 p., 2008.
- [12] U.S. Coast Guard Navigation Center, Global Positioning System – Standard Positioning Service Signal Specification, 2<sup>nd</sup> Ed., 51 p., 1995.
- [13] D. Collins and S. Clint, 3G Wireless Networks. McGraw-Hill Professional, USA, 642 p., 2001.
- [14] K. Pahlavan and P. Krishnamurthy, Principles of Wireless Networks: A Unified Approach. Prentice Hall, USA, 581 p., 2002.
- [15] 3GPP TS 25.102, Technical Specification Group GSM/EDGE Radio Access Network; Radio Transmission and Reception, Release 8, Ver. 8.4.0, 180 p., 2009.
- [16] 3GPP TS 25.102, Technical Specification Group Radio Access Network; User Equipment (UE) Radio Transmission and Reception (FDD), Release 8, Ver. 8.6.0, 209 p., 2009.
- [17] 3GPP TS 25.102, Technical Specification Group Radio Access Network; User Equipment (UE) Radio Transmission and Reception (TDD), Release 8, Ver. 8.3.0, 168 p., 2009.
- [18] The Electronic Communication Committee, Decision on the Harmonized Utilisation of Spectrum for Terrestrial IMT-2000/UMTS System Operating Within the Bands 1900 – 1980 MHz, 2010 – 2025 MHz and 2110 – 2170 MHz. Doc: ECC/DEC/(06)01, 6 p., 2006.
- [19] S.R. Saunders, Antennas and Propagation for Wireless Communication Systems. John Wiley & Sons Ltd, England, 409 p., 1999.
- [20] J.G. Proakis, Digital Communications. McGraw-Hill, 4<sup>th</sup> Ed., 1002 p., 2001.
- [21] A. Goldsmith, Wireless Communications. Cambridge University Press, 672 p., 2005.
- [22] R. van Nee and R. Prasad, OFDM for Wireless Multimedia Communications. Artech House, 260 p., 2000.
- [23] S. Zhou, G.B. Giannakis and A. Swami, Digital Multi-Carrier Spread Spectrum Versus Direct Sequence Spread Spectrum for Resistance to Jamming and Multipath. IEEE Trans. on Comm., Vol. 50, No. 4, pp. 643 – 655, 2002.
- [24] A. van Zelst, MIMO-OFDM for Wireless LANs. Doctoral Thesis, University of Eindhoven, the Netherlands, 229 p., 2004.
- [25] Wolfram Mathworld. [Online]. Available at: <http://mathworld.wolfram.com/>.
- [26] D. Gesbert, MIMO Space-time Coded Wireless Systems. Lecture material, Dept. of Informatics, University of Oslo, Norway, 2003.

- [27] S. Lin and D.J. Costello Jr., Error Control Coding: Fundamentals and Applications. Prentice-Hall, Inc., 603 p., 1983.
- [28] B. Sklar and F.J. Harris, The ABCs of Linear Block Codes. IEEE Signal Processing Magazine, Vol. 21, Iss. 4., pp. 14 – 35, 2004.
- [29] C. Berrou, A. Glavieux and P. Thitimajshima, Near Shannon Limit Error-Correcting Coding and Decoding: Turbo-Codes. In Proc. of ICC'93, pp. 54 – 58, 1993.
- [30] R.G. Gallager, Low-Density Parity-Check Codes. IRE Transactions on Information Theory, Vol. 8, Iss. 1, pp. 21 – 28, 1962.
- [31] ECMA International, Standard ECMA-368: High Rate Ultra Wideband PHY and MAC Standard. 1<sup>st</sup> Ed., 326 p., 2005.
- [32] WiMedia Alliance. [Online]. Available at: <http://www.wimedia.org/>.
- [33] S.M. Mishra, S. ten Brink, R. Mahadevappa and R.W. Brodersen, Detect and Avoid: An Ultra-Wideband/WiMax Coexistence Mechanism. IEEE Comm. Magazine, pp. 68 – 75, June, 2007.
- [34] EE Times, Wireless USB Startup WiQuest Folds. [Online]. Available at: <http://www.eetimes.com/showArticle.jhtml?articleID=211800613>, Oct., 2008.
- [35] EE Times, Intel Cancels Ultrawideband Design Effort. [Online]. Available at: <http://www.eetimes.com/showArticle.jhtml?articleID=212000285>, Nov., 2008.
- [36] EE Times, UWB Startup Tzero Shuts Down. [Online]. Available at: <http://www.eetimes.com/showArticle.jhtml?articleID=213900881>, Feb., 2009.
- [37] EE Times India, Staccato CEO Sets the Record Straight on UWB. [Online]. [http://www.eetindia.co.in/ART\\_8800564171\\_1800005\\_NT\\_e3eaa37f.HTM](http://www.eetindia.co.in/ART_8800564171_1800005_NT_e3eaa37f.HTM), Feb., 2009.
- [38] EE Times India, UWB Gone by 2013. [Online]. Available at: [http://www.eetindia.co.in/ART\\_8800571562\\_1800005\\_NT\\_6b806dd1.HTM](http://www.eetindia.co.in/ART_8800571562_1800005_NT_6b806dd1.HTM), May, 2009.
- [39] ZigBee Alliance. [Online]. Available at: <http://www.zigbee.org/>.
- [40] IEEE Standard for Local and Metropolitan Area Networks: Part 15.4: Wireless Access Control (MAC) and Physical Layer (PHY) Specifications for Low-Rate Wireless Personal Area Networks (WPANs). Doc: IEEE Std 802.15.4-2006, 323 p., 2006.
- [41] IEEE Standard for Local and Metropolitan Area Networks: Part 15.4: Wireless Access Control (MAC) and Physical Layer (PHY) Specifications for Low-Rate Wireless Personal Area Networks (WPANs). Amendment 1: Add Alternate PHYs. Doc: IEEE Std 802.15.4a-2007, 203 p., 2007.
- [42] ZigBee Alliance, ZigBee Specification. Doc: 053474r17, 604 p., 2008.
- [43] ZigBee Alliance, ZigBee and Wireless Radio Frequency Coexistence. [Online]. Available at: [http://www.zigbee.org/imwp/idms/popups/pop\\_download.asp?contentID=11745](http://www.zigbee.org/imwp/idms/popups/pop_download.asp?contentID=11745).
- [44] Schneider Electric, ZigBee – WiFi Coexistence. [Online]. Available at: [http://www.zigbee.org/imwp/idms/popups/pop\\_download.asp?contentID=13184](http://www.zigbee.org/imwp/idms/popups/pop_download.asp?contentID=13184).
- [45] IEEE 802.15 WPAN Task Group 1 (TG1). [Online]. Available at: <http://www.ieee802.org/15/pub/TG1.html>.
- [46] Bluetooth Special Interest Group (SIG). [Online]. Available at: <http://www.bluetooth.com/>.
- [47] IEEE Standard for Local and Metropolitan Area Networks: Part 11: Wireless LAN Medium Access Control (MAC) and Physical Layer (PHY) Specifications. Doc: IEEE Std 802.11-2007, 1232 p., 2007.
- [48] Bluetooth SIG, Bluetooth Specification V3.0 + HS. 1712 p., 2009.
- [49] ZDNet UK, Bluetooth 3.0 Released Without Ultrawideband. [Online]. Available at: <http://news.zdnet.co.uk/communications/0,1000000085,39643174,00.htm>, April, 2009.
- [50] M. Song, S. Shetty and D. Gopalpet, Coexistence of IEEE 802.11b and Bluetooth: An Integrated Performance Analysis. Mobile Networks and Applications, Vol. 12, pp. 450 – 459, 2007.
- [51] N. Golmie, N. Chevrollier and O. Rebala, Bluetooth and WLAN Coexistence: Challenges and Solutions. IEEE Wireless Comm., Vol. 10, Iss. 6, pp. 22-29, 2003.
- [52] A. Conti, D. Dardari, G. Pasolini and O. Andrisano, Bluetooth and IEEE 802.11b Coexistence: Analytical Performance Evaluation in Fading Channels. IEEE JSAC, Vol. 21, No. 2, pp. 259 – 269, 2003.
- [53] N. Golmie, R.E. Van Dyck, A. Soltanian, A. Tonnerre and O. Rebala, Interference Evaluation of Bluetooth and IEEE 802.11b Systems. Wireless Networks, Vol. 9, No. 3, pp. 201 – 211, 2003.

- [54] NIST, Wireless Network Security: 802.11, Bluetooth and Handheld Devices. Doc: 800-48, 119 p., 2002.
- [55] European Radiocommunications Committee (ERC), ERC Decision on the Harmonized Frequency Bands to be Designated for the Introduction of High Performance Radio Local Area Networks (HIPERLANs). Doc: ERC/DEC/(99)23, 7 p., 1999.
- [56] IEEE P802.11 – Task Group N – Meeting Update. [Online]. Available at: [http://www.ieee802.org/11/Reports/tgn\\_update.htm](http://www.ieee802.org/11/Reports/tgn_update.htm)
- [57] T. Paul and T. Ogunfunmi, Wireless LAN Comes of Age: Understanding the IEEE 802.11n Amendment. IEEE Circuits and Systems Magazine, Vol. 8, Iss. 1, pp. 28 – 54, 2008.
- [58] IEEE 802.11 Task Group N, 11n 40 MHz and BT Coexistence Test Results. Doc: IEEE 802.11-08/1140r0.
- [59] IEEE 802.11 Task Group N, Measurements of Coexistence Between 802.11n 40MHz and Bluetooth. Doc: IEEE 802.11-08/0893r0.
- [60] IEEE 802.11 Task Group N, IEEE 802.11n 40 MHz Impact on BT Performance. Doc: IEEE 19-08-0027-02-0000-40MHz-11n-impact-on-bluetooth.
- [61] IEEE 802.11 Task Group N, Measurements of Coexistence Between 802.11n 40 MHz and Bluetooth SCO. Doc: IEEE 802.11-08/1132r0.
- [62] Wi-Fi Alliance. [Online]. Available at: <http://www.wi-fi.org/>.
- [63] R. Want, An Introduction to RFID Technology. IEEE Pervasive Computing, Vol. 5, Iss. 1, pp. 25 – 33, 2006.
- [64] ECMA International, Near Field Communication – White Paper. Doc: Ecma/TC32-TG19/2004/01, 9 p., 2004.